

1 **BILL NO. S-24-01-06**

2 SPECIAL ORDINANCE NO. S- 4-24

3 AN ORDINANCE approving SERVICES AGREEMENT  
4 – 2024 ANNUAL ON-CALL ASPHALT CUT REPAIR  
5 SERVICES (not to exceed \$405,000.00) between  
6 ROBBCO, INC. and the City of Fort Wayne, Indiana, by  
7 and through its Division of City Utilities.

8 **NOW, THEREFORE, BE IT ORDAINED BY THE COMMON**  
9 **COUNCIL OF THE CITY OF FORT WAYNE, INDIANA:**

10 **SECTION 1.** That the SERVICES AGREEMENT - 2024 ANNUAL  
11 ON-CALL ASPHALT CUT REPAIR SERVICES (not to exceed \$405,000.00)  
12 between ROBBCO, INC. and the City of Fort Wayne, Indiana, by and through its  
13 Division of City Utilities, is hereby ratified, and affirmed and approved in all  
14 respects, respectfully for:

15 2024 ANNUAL ON-CALL ASPHALT CUT REPAIR SERVICES;  
16 involving a total cost not-to-exceed FOUR HUNDRED FIVE THOUSAND AND  
17 00/100 DOLLARS - (\$405,000.00). A copy of said Contract is on file with the Office  
18 of the City Clerk and made available for public inspection, according to law.

19 **SECTION 2.** That this Ordinance shall be in full force and effect from  
20 and after its passage and any and all necessary approval by the Mayor.

21   
22 \_\_\_\_\_  
23 Council Member

24 APPROVED AS TO FORM AND LEGALITY

25   
26 \_\_\_\_\_  
27 Malak Heiny, City Attorney

28  
29  
30

Approval of Services Agreement between the City of Fort Wayne Utilities and Robbco, Inc for Annual On-Call Asphalt Cut Repair Services for 2024. Compensation for services performed shall be a not-to-exceed amount of \$405,000.

City of Fort Wayne  
Board of Public Works

Date: 12.19.2023

  
Shan Gunawardena, Chair

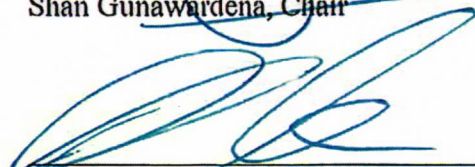
  
Kumar Menon, Member

  
Chris Guerrero, Member

Attest:   
Michelle Fulk-Vondran, Clerk



SERVICE AGREEMENT: \_\_\_\_\_

SUPPLIER NAME Robbco, Inc		CITY DEPARTMENT City of Fort Wayne Utilities	
STREET ADDRESS 6608 Bradbury Ave		STREET ADDRESS 200 East Berry St.	
CITY, STATE, ZIP CODE Fort Wayne, IN 46809		CITY, STATE, ZIP CODE Fort Wayne, IN 46802	
ATTENTION Alfred Chambers		INVOICE ADDRESS 415 East Wallace Street or 515 East Wallace Street	
TELEPHONE (260) 747-2769	FAX	CITY, STATE, ZIP CODE Fort Wayne, IN 46802	
REMIT-TO ADDRESS		ATTENTION Chris Brown	
CITY, STATE, ZIP CODE		TELEPHONE (260) 427-1363	FAX 260-427-1282

Service Description	Rates
<b>2024 Annual On-Call Asphalt Cut Repair Services</b>	
<b>Aggregate Price</b>	<b>\$405,000.00</b>

AGREEMENT START DATE <b>1/1/2024</b>
AGREEMENT END DATE <b>12/31/2024</b>

This Agreement is entered into between Supplier and City Utilities as of January 1, 2022. The additional terms and conditions on the reverse side hereof are part of this Agreement. Capitalized terms on this page are used as defined terms when the context so requires. The City may extend the Contract at its option, for an equivalent period, by written notice to the Supplier not less than thirty days prior to the expiration date.

SUPPLIER: Robbco, Inc

By (Signature): <i>Alfred Chambers</i>
Printed Name: ALFRED CHAMBERS
Title: VICE PRESIDENT
Date: 1-2-13-23
FEDERAL TAX ID NUMBER: 35-1850232

ADDITIONAL TERMS AND CONDITIONS

1. **SERVICES.** Supplier agrees to perform the Services beginning on the Begin Date and continuing until the Services are completed. Supplier warrants that the Services will be completed on or before the End Date. **TIME IS OF THE ESSENCE.** Supplier warrants that all Services shall conform to the Service Description, be of good quality and workmanship, and be free from defects. Supplier further warrants that all goods furnished in connection with the Services shall be merchantable and suitably safe and sufficient for the purpose for which they are normally used. Supplier warrants that it has good title to goods supplied hereunder and that they are free of all liens and encumbrances. These warranties are in addition to those implied in fact or in law. For the purposes of this Agreement, the term "Services" shall include any goods furnished in connection with the Services.
2. **INVOICES.** Supplier shall invoice the City for Services performed according to the Rates, Billing Interval, and Invoice Address. Invoices shall be rendered in triplicate and shall itemize the Services performed, the Service Address, and the corresponding rates and taxes, if any. Payment shall be due within thirty (30) days after the invoice date or the date of completion of the invoiced Services, whichever occurs later, provided that the City shall not be obligated to make any payment to Supplier hereunder until Supplier has furnished proof satisfactory to the City of full payment for all labor, materials, supplies, machinery, and equipment furnished for or used in performance of this Agreement or has furnished all necessary waivers of lien supported by affidavits, all satisfactory to the City, establishing that all liens and rights to claim liens that could arise out of the performance of the Services have been waived. Payment of invoices shall not constitute acceptance of the Services, and invoices shall be subject to adjustment for defects in quality or any other failure of Supplier to meet the requirements of this Agreement. The City may at any time set off any amount owed by the City to supplier against any amount owed by Supplier or any of its affiliated companies to the City.
3. **INDEPENDENT CONTRACTOR RELATIONSHIP.** City and Supplier are and shall remain as independent contractors with respect to each other. The persons provided by Supplier to perform the Services shall be Supplier's employees and shall be under the sole and exclusive direction and control of Supplier. They shall not be considered employees of the City for any purpose. Supplier shall be responsible for compliance with all laws, rules and regulations involving, but not limited to, employment of labor, hours of labor, health and safety, working conditions, and payment of wages with respect to such persons. Supplier shall also be responsible for payment of taxes, including federal, state and municipal taxes chargeable or assessed with respect to its employees, such as Social Security, unemployment, Workers' Compensation, disability insurance, and federal and state withholding. Supplier shall also be responsible for providing such reasonable accommodations, including auxiliary aids and services, as may be required under the Americans With Disabilities Act, 42 U.S.C. 12101 et seq., so as to enable any disabled person furnished by Supplier to perform the essential functions of the job. Supplier agrees to defend, indemnify, and hold harmless the City from and against any loss, cost, claim, liability, damage, or expense (including attorney's fees) that may be sustained by reason of Supplier's failure to comply with this paragraph.
4. **INDEMNITY.** Supplier shall defend, indemnify, and hold harmless the City (including its officers, employees, and agents) from all demands, damages, liabilities, costs, and expenses (including reasonable attorney's fees), judgments, settlements, and penalties of every kind arising out of its performance of Services including, without limitation, damages for personal injury or death or loss or damage to property due, or claimed to be due, to the negligence or willful misconduct of Supplier including such portion thereof due, or claimed to be due, to the negligence of the City except that Supplier shall have no duty to hold harmless the City for such portion of the foregoing proximately caused by negligence or misconduct of the City, and if any suit, claim, or demand was defended by Supplier, then the City will reimburse Supplier for its pro-rata share of its costs, expenses (including reasonable attorney's fees), and damages. The City may elect to participate in the defense of any suit, claim, or demand by employing attorneys at its own expense, without waiving Supplier's obligations to indemnify, defend, or hold harmless. Supplier shall not settle or compromise any claim, suit, or action, or consent to entry of judgment without the prior written consent of the City and without an unconditional release of all liability by each claimant or plaintiff to the City.
5. **LIMITATION OF LIABILITY.** Each party's liability to the other for any loss, cost, claim, liability, damage, or expense (including attorneys' fees) relating to or arising out of any negligent act or omission in its performance of obligations arising out of this Agreement, shall be limited to the amount of direct damage actually incurred. Absent gross negligence or knowing and willful misconduct which causes a loss, neither party shall be liable to the other for any indirect, special or consequential damage of any kind whatsoever.
6. **INSURANCE.** Supplier shall maintain in full force and effect during the performance of the Services the following insurance coverage; provided, however, that if a High Risk Insurance Attachment us attached hereto, the requirements of the High Risk Insurance Attachment shall be substituted in lieu of the following requirements:
 

(a) Worker's Compensation	per statutory requirements.
(b) General Liability	\$2,000,000 minimum per occurrence/ \$5,000,000 aggregate
(c) Automobile Liability	\$1,000,000 minimum per occurrence
(d) Products Liability	\$1,000,000 minimum per occurrence
(e) Completed Operations Liability	\$1,000,000 minimum per occurrence

The Certificate of Insurance must show the City of Fort Wayne, its Divisions and Subsidiaries as an Additional Insured and a Certificate Holder, with 30 days notification of cancellation or non-renewal. All Certificates of Insurance should be sent to the following address:  
City of Fort Wayne Purchasing Department  
1 East Main Street, Rm 350  
Fort Wayne, IN 46802
7. **HAZARDOUS MATERIALS.** Supplier will provide to the City before performing any Services, a statement describing any Hazardous Materials intended and necessary for use in performing the Services. "Hazardous Materials" means any item which may be classified under federal, state, or local law, as hazardous or toxic. Supplier must comply with all federal, state, or local law in the use, transportation, and disposal of such Hazardous Materials.
8. **PROGRESS REPORTS.** The Supplier shall submit progress reports to the City upon request. The report shall serve the purpose of assuring the City that work is progressing in line with the schedule, and that completion can be reasonably assured on the scheduled date. This contract shall be deemed to the substantially performed only when fully performed according to its terms and conditions and any modification thereof.
9. **CONFLICT OF INTEREST.** Supplier certifies and warrants that neither it nor any of its directors, officers, agents, representatives or employees which will participate in any way in the performance of the Supplier's obligations hereunder has or will have any conflict of interest, direct or indirect, with the City of Fort Wayne or any of its departments, divisions, agencies, officers, directors or agents.
10. **CONFIDENTIALITY OF DATA, PROPERTY RIGHTS IN PRODUCTS, AND COPYRIGHT PROHIBITION.** Supplier further agrees that all information, data findings, recommendations, proposals, etc. by whatever name described and by whatever form therein secured, developed, written or produced by the Supplier in furtherance of this contract—shall be the property of the City. The Supplier shall take action as is necessary under law to preserve such property rights in and of the City while such property is within the control and/or custody of the Supplier. If by this contract the Supplier specifically waives and/or releases to the City any cognizable property right of the Supplier to copyright, license, patent or other wise use such information, data findings, recommendations proposals, etc.
11. **CONFIDENTIALITY OF CITY INFORMATION.** Supplier understands and agrees that data, materials, and information disclosed to Supplier may contain confidential and protected data. Therefore, the Supplier promises and assures that data, material, and information gathered, based upon or disclosed to the Supplier for the purpose of this contract, will not be disclosed to others or discussed with other parties without the prior written consent of the City.
12. **COMPLIANCE WITH LAWS.** Supplier warrants that the Services shall be in strict conformity with all applicable local, state and federal laws including, but not limited to, the standards promulgated by the occupational Safety and Health Act, Executive Order 11246, as amended, relative to Equal Employment Opportunity and all other applicable laws, rules, and regulations, including the Civil Rights Act of 1964 pertaining to equal opportunity, Section 503 of the Vocational Rehabilitation Act of 1973, the American with Disabilities Act, Section 402 of the Vietnam Era Veterans Readjustment Assistance Act of 1974 and all applicable immigration laws and regulations including the 1986 Immigration Reform and Control Act et. seq. Supplier agrees to indemnify and hold harmless the City from and against any loss, cost, claim, liability, damage, or expense (including attorney's fees) that may be sustained because of Supplier's breach of such warranty.
13. **DEFAULT.** In the event that (a) Supplier breaches any warranty contained herein; (b) Supplier fails to provide the insurance certificate required herein; (c) Supplier or Supplier's insurance carrier fails to defend, indemnify, or hold harmless the City as required herein; (d) Supplier's performance of the Services violates applicable law; (e) Supplier admits insolvency, makes an assignment for the benefit of creditors, or has a trustee appointed to take over all or a substantial part of its assets; or (f) Supplier fails to perform or comply with any other provision of this Agreement, such failure, breach, or violation shall constitute a default under this Agreement.
14. **TERMINATION.** In the event of default by Supplier under this Agreement, the City reserves the right without liability, in addition to its other rights and remedies, to terminate this Agreement by notice to Supplier as to the portion of the Services not yet rendered and to purchase substitute services at Supplier's expense. Supplier shall reimburse the City for the cost of such substitute services upon Supplier's receipt of an invoice therefor.
15. **WAIVER.** No action or inaction by the City shall constitute a waiver of any right or remedy.
16. **CANCELLATION.** City may at any time cancel this Agreement in whole or in part for its sole convenience upon written notice to Supplier, and Supplier shall stop performing the Services on the date specified in such notice. The City shall have no liability as a result of such cancellation, except that the City will pay Supplier the Rates for completed Services accepted by the City and the actual incurred cost to Supplier for Services in progress. These payments shall not exceed the Aggregate Price.
17. **FORCE MAJEURE.** Neither party shall be liable to the other or responsible for nonperformance of any of the terms of this Agreement due to unforeseeable causes beyond the reasonable control and without the fault or negligence of such party, including, but not restricted to acts of God or the public enemy, acts of government, fire, floods, epidemics, quarantine restrictions, strikes, freight embargoes, or unusually severe weather.
18. **NOTICES.** All notices required or permitted to be made or given hereunder by one party to the other party shall be in writing and shall be deemed to have been given when hand delivered, or on the date stated on the receipt if deposited in the United States mail in certified form, postage prepaid with return receipt requested, and addressed to such other party at its Notice Address or at such other address as may be specified by such other party by written notice sent or delivered in accordance herewith.
19. **ASSIGNMENT.** Any assignment, in whole or in part, of Supplier's rights or obligation under this Agreement without the prior written consent of the City shall be void. Supplier shall not use subcontractors to perform any part of the Services without the prior written consent of the City.
20. **DISPUTE RESOLUTION.** The City shall be the sole judge of the quality of services. In the event of any dispute or disagreement between the parties either with respect to the interpretation of any provision of this agreement, or with respect to the performance of either party hereunder, the dispute shall be resolved by the Director of Finance and Administration and will not be subject to arbitration.
21. **ACCESS TO RECORDS.** The Supplier shall maintain all books, documents, papers, accounting records, and other evidence pertaining to the cost incurred. They shall make such materials available at their respective offices at all reasonable times during the contract period and for three (3) years from the date of final payment under the contract for inspection by the City or by any other authorized representative of city government. Copies thereof shall be furnished at no cost to the City if requested.
22. **NONDISCRIMINATION.** Pursuant to IC 22-9-1-10 and the Civil Rights Act of 1964, Supplier and its subcontractors shall not discriminate against any employee or applicant for employment in the performance of this contract. The Supplier shall not discriminate with respect to hire, tenure, terms, conditions or privileges of employment or any matter directly or indirectly related to employment, because of race, color, religion, sex, disability, national origin or ancestry. Breach of this covenant may be regarded as a material breach of contract. Acceptance of this contract also signifies compliance with applicable Federal laws, regulations, and executive orders prohibiting discrimination in the provision of services based on race, color, national origin, age, sex, disability or status as a veteran.
23. **MISCELLANEOUS.** If any provision of this Agreement is held to be invalid or unenforceable, the validity and enforceability of the remaining provisions shall not be affected. This Agreement shall be governed by the laws of the state of Indiana and shall be subject to the exclusive jurisdiction of the courts therein. This Agreement embodies the entire agreement between the parties with respect to the subject matter hereof and supersedes all prior agreements and understanding, whether written or oral, and all contemporaneous oral agreements and understandings relating to the subject matter hereof. No agreement hereafter made shall be effective to modify or discharge this Agreement, in whole or in part, unless such agreement is in writing and signed by the party against whom enforcement of the modification or discharge is sought. The paragraph headings are for convenience only and are not intended to affect the interpretation of the provisions hereof. This agreement shall be binding on the parties hereto and their respective personal and legal representatives, successors and assigns.

# Asphalt and Park Strip Bid Form

	Asphalt	Price per Sq Ft
1	50 Sq ft or less Secondary Street	12.36
2	51 to 100 Sq Ft Secondary Street	11.89
3	101 sq ft and larger Secondary Street	11.28
4	50 Sq ft or less Primary roadway	13.27
5	51 to 100 Sq Ft Primary Roadway	12.36
6	101 sq ft and larger Primary Roadway	12.14
	Park Strip restoration	Price per Sq Ft
7	50 Sq Ft or less	4.16
8	51 to 100 Sq Ft	3.79
9	101 Sq Ft or larger	3.41



**CONTRACTOR'S BID FOR PUBLIC WORK - FORM 96**  
 State Form 52414 (R2 / 2-13) / Form 96 (Revised 2013)  
 Prescribed by State Board of Accounts

# 110-11-7-23-1  
 Robbco

**PART I**

(To be completed for all bids. Please type or print)

Date (month, day, year): 11/29/23

1. Governmental Unit (Owner): Board of Public Works, City of Fort Wayne
2. County: Allen
3. Bidder (Firm): Robbco, Inc.  
 Address: P.O. Box 9302  
 City/State/ZIP code FW, IN 46899
4. Telephone Number: 260 - 747-2769
5. Agent of Bidder (if applicable): \_\_\_\_\_

Pursuant to notices given, the undersigned offers to furnish labor and/or material necessary to complete the public works project of Board of Public Works, City of Fort Wayne (Governmental Unit) in accordance with plans and specifications prepared by Fort Wayne City Utility Operations entitled Concrete Cut Repairs Services and dated 11/29/23 for the sum of \_\_\_\_\_ \$ See bid tab

The undersigned further agrees to furnish a bond or certified check with this bid for an amount specified in the notice of the letting. If alternative bids apply, the undersigned submits a proposal for each in accordance with the notice. Any addendums attached will be specifically referenced at the applicable page.

If additional units of material included in the contract are needed, the cost of units must be the same as that shown in the original contract if accepted by the governmental unit. If the bid is to be awarded on a unit basis, the itemization of the units shall be shown on a separate attachment.

The contractor and his subcontractors, if any, shall not discriminate against or intimidate any employee, or applicant for employment, to be employed in the performance of this contract, with respect to any matter directly or indirectly related to employment because of race, religion, color, sex, national origin or ancestry. Breach of this covenant may be regarded as a material breach of the contract.

**CERTIFICATION OF USE OF UNITED STATES STEEL PRODUCTS**  
 (If applicable)

I, the undersigned bidder or agent as a contractor on a public works project, understand my statutory obligation to use steel products made in the United States (1.C. 5-16-8-2). I hereby certify that I and all subcontractors employed by me for this project will use U.S. steel products on this project if awarded. I understand that violations hereunder may result in forfeiture of contractual payments.

ACCEPTANCE

The above bid is accepted this 29 day of November, subject to the

following conditions: NONE

Contracting Authority Members:

\_\_\_\_\_  
 \_\_\_\_\_  
 \_\_\_\_\_

PART II

(For projects of \$150,000 or more - IC 36-1-12-4)

Governmental Unit: City of Fox Wayne  
 Bidder (Firm) Rodoco, Inc.  
 Date (month, day, year): 11/29/2023

These statements to be submitted under oath by each bidder with and as a part of his bid.  
 Attach additional pages for each section as needed.

SECTION I EXPERIENCE QUESTIONNAIRE

1. What public works projects has your organization completed for the period of one (1) year prior to the date of the current bid?

Contract Amount	Class of Work	Completion Date	Name and Address of Owner
<u>on going open</u>	<u>Concrete</u>	<u>12/31/23</u>	<u>CITY of Fox Wayne</u>

2. What public works projects are now in process of construction by your organization?

Contract Amount	Class of Work	Expected Completion	Name and Address of Owner

3. Have you ever failed to complete any work awarded to you? NO If so, where and why?

---

---

---

4. List references from private firms for which you have performed work.

Key Concrete Inc. / Robert Stark

---

---

---

---

SECTION II PLAN AND EQUIPMENT QUESTIONNAIRE

1. Explain your plan or layout for performing proposed work. (Examples could include a narrative of when you could begin work, complete the project, number of workers, etc. and any other information which you believe would enable the governmental unit to consider your bid.)

Remove existing materials and  
replace as required by contract.

---

---

---

2. Please list the names and addresses of all subcontractors (i.e. persons or firms outside your own firm who have performed part of the work) that you have used on public works projects during the past five (5) years along with a brief description of the work done by each subcontractor.

yes

---

---

---

---

3. If you intend to sublet any portion of the work, state the name and address of each subcontractor, equipment to be used by the subcontractor, and whether you will require a bond. However, if you are unable to currently provide a listing, please understand a listing must be provided prior to contract approval. Until the completion of the proposed project, you are under a continuing obligation to immediately notify the governmental unit in the event that you subsequently determine that you will use a subcontractor on the proposed project.

NO

4. What equipment do you have available to use for the proposed project? Any equipment to be used by subcontractors may also be required to be listed by the governmental unit.

Dymptwicks  
Backhoe  
Bobcat

5. Have you entered into contracts or received offers for all materials which substantiate the prices used in preparing your proposal? If not, please explain the rationale used which would corroborate the prices listed.

yes

### SECTION III CONTRACTOR'S FINANCIAL STATEMENT

Attachment of bidder's financial statement is mandatory. Any bid submitted without said financial statement as required by statute shall thereby be rendered invalid. The financial statement provided hereunder to the governing body awarding the contract must be specific enough in detail so that said governing body can make a proper determination of the bidder's capability for completing the project if awarded.

SECTION IV CONTRACTOR'S NON-COLLUSION AFFIDAVIT

The undersigned bidder or agent, being duly sworn on oath, says that he has not, nor has any other member, representative, or agent of the firm, company, corporation or partnership represented by him, entered into any combination, collusion or agreement with any person relative to the price to be bid by anyone at such letting nor to prevent any person from bidding nor to include anyone to refrain from bidding, and that this bid is made without reference to any other bid and without any agreement, understanding or combination with any other person in reference to such bidding.

He further says that no person or persons, firms, or corporation has, have or will receive directly or indirectly, any rebate, fee, gift, commission or thing of value on account of such sale.

SECTION V OATH AND AFFIRMATION

I HEREBY AFFIRM UNDER THE PENALTIES FOR PERJURY THAT THE FACTS AND INFORMATION CONTAINED IN THE FOREGOING BID FOR PUBLIC WORKS ARE TRUE AND CORRECT.

Dated at Fort Wayne this 29 day of November

Robeco, Inc.

(Name of Organization)

By

Alfred Chambers

Vice President

(Title of Person Signing)

ACKNOWLEDGEMENT

STATE OF Indiana,  
COUNTY OF Allen } ss

Before me, a Notary Public, personally appeared the above-named Alfred Chambers and swore that the statements contained in the foregoing document are true and correct.

Subscribed and sworn to before me this 29 day of November

Abigail Stark  
Notary Public

My Commission Expires: 3-28-2024

County of Residence: Allen

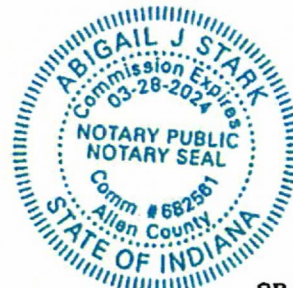

BID OF  
Robbco, Inc. (Contractor)  
P.O. Box 9302  
FW, IN 46899 (Address)

FOR  
PUBLIC WORKS PROJECTS  
OF

\_\_\_\_\_  
\_\_\_\_\_  
\_\_\_\_\_

Filed \_\_\_\_\_

Action taken \_\_\_\_\_

\_\_\_\_\_  
\_\_\_\_\_

CITY UTILITIES ANNUAL ON-CALL ASPHALT CUT REPAIR SERVICES  
RESOLUTION NO. 110-11-7-23-1

RESOLUTION BY THE BOARD OF PUBLIC WORKS of the City of Fort Wayne, Indiana that:

Fort Wayne Utilities is requesting time and material quotes for contracting various types of labor and equipment for repairs of Asphalt Cuts made by the Utilities in the repair of the distribution and collection systems. All repairs are to be made to the Transportation Engineering Standards dated 8-27-15.

Said services shall be constructed in accordance with the plans and specifications.

APPROVED THIS 7 DAY OF November, 2023

BOARD OF PUBLIC WORKS

BY:

  
Shan Gunawardena, Chair

BY:

ABSENT

Kumar Menon, Member

BY:

  
Chris Guerrero, Member

ATTEST:

  
Michelle Fulk-Vondran, Clerk

**News Paper announcement for Asphalt Cut Repair Services:**

Fort Wayne City Utilities  
Asphalt Cut Repair Services  
Res #110-11-7-23-1

Fort Wayne City Utilities is requesting time and material quotes for contracting various types of labor and equipment for repair of asphalt cuts made by the City to repair infrastructure. Such repairs include 25 sq., 50 sq. Ft. and 100 sq. ft. (plus) areas. All Quotes to be to the Transportation Engineering Standards dated 8-27-15.

It is the intent of the Utility, for purposes of getting caught up and to maintain a minimal backlog of these types of restorations to have a list of available contractor(s) names and numbers accessible to the Utility.

Terms of agreement are **January 1, 2024 through December 31, 2024**, on an "as needed" basis. This quote does not guarantee work to any contractor within the above time frame. The Utility reserves the right to award work to multiple contractors based upon the availability of the contractor(s), projected costs of the repair and the amount and type of work that needs to be performed.

A pre-bid for this contract will be held on **November 30, 2023 at 2:30 pm at the Water Maintenance and Service Department located at 415 East Wallace Street in the Conference Room, Fort Wayne Indiana.**

Sealed Bids are due to the Board of Public Works Quest site no later than 2:00 pm, December 7, 2023. Contractors will be notified of making the list by **January 1, 2024.**

Bidding Information can only be downloaded at <http://bidding.cityoffortwayne.org/city.php> and/or [www.questcdn.com](http://www.questcdn.com). Contractors may view the contract documents at no cost prior to becoming a Planholder. Contact QuestCDN Customer Support at 952-233-1632 or [info@questcdn.com](mailto:info@questcdn.com) for assistance in membership registration, and downloading digital project information

**The QuestCDN eBidDoc Number for this project is: 8803435**

No Bid may be withdrawn for at least 60 days after the scheduled time for receipt of Bids so as to allow review of Bids before announcing award of Contract. The successful Bidder will be required to furnish a satisfactory Labor and Material Payment Bond and Performance Bond each in the amount no less than one hundred (100%) percent of the contract price.

The Board reserves the right to reject any and all bids for failure to comply with applicable laws and/or with the Instructions to Bidders. The Board also reserves the right to waive any defect in any bid.

**ATTEST: Michelle Fulk-Vondran, Clerk**

**Publish: November 9, 2023 & November 16, 2023 in the Journal Gazette.**

**CITY UTILITIES ANNUAL ON-CALL ASPHALT RESTORATION SERVICES**  
**REQUIREMENTS TO PROVIDE LABOR AND EQUIPMENT FOR**  
**REPAIRS TO ASPHALT CUTS TO REPAIR FORT WAYNE UTILITY SYSTEMS**  
**INFRASTRUCTURES**

**Scope of Work:**

Fort Wayne Utilities is requesting time and material quotes for contracting various types of labor and equipment for repairs to Asphalt Cuts made by the Utilities in the repair of the distribution and collection systems. Such repairs may include, sawing the original cut, excavating cold patch and fill, adding and compacting binder and Asphalt top coat per City street specifications, to bring the repair back to specification and proper level with minimal level differential to cause issues with traffic... All repairs are to be made to the Transportation Engineering Standards dated 8-27-15

It is the intent of the Utility, for purposes of emergencies, to have a list of available contractor(s) names, emergency numbers, and equipment accessible to the Utility.

Term of agreement: January 1, 2024 through December 31, 2024, on an "as needed" basis. This quote does not guarantee work to any contractor within the above time frame. The Utility reserves the right to award work to multiple contractors based upon the availability of the contractor(s), projected costs of the project and the amount and type of work that needs to be performed.

**Contractor Responsibilities:**

The contractor shall furnish equipment as necessary to complete the repairs as outlined by Utility Maintenance staff or Utility Engineering. One or more pieces of fully operated equipment, as deemed necessary by the Utility including operator, complete maintenance, insurance, fuel and oil may be needed for the work to be performed. Equipment shall meet all requirements necessary for safe and efficient operation, as determined by Utility Maintenance staffs.

In emergency situations needing immediate attention and work, requests for locates may be called into Indiana Underground Plant Protection (IUPPS) by Water Maintenance & Service or Water Pollution Control Maintenance Departments prior to calling a contractor. The Contractor will be notified as to the status of the locate request. This in no way relieves the liability of the contractor for damaging utilities. The contractor shall not commence excavation until all utilities have located their facilities. On planned / scheduled work, the contractor shall be required to contact IUPPS with the pertinent information regarding the proposed excavation.

The contractor shall furnish experienced and competent operators, laborers, and supervisors having sufficient knowledge of Fort Wayne Utility Standards and Specifications and Street Standards and Specifications. Supervisors/forepersons shall be able to follow verbal and/or written instructions on the type of repairs required. Laborers shall be experienced with Asphalt installation and repair techniques. All operators shall be properly licensed.

The contractor shall indemnify and hold harmless the City of Fort Wayne, Indiana, its officers and employees, from all damages, claims, suits, and actions of any descriptions, for or resulting from injuries or damages received or sustained by any party or parties arising out of any act or failure to act, of said contractor, or his agents, in the execution of work under the contract.

The contractor shall be responsible for adherence to all OSHA regulations for trenching and shoring. In addition, contractor shall provide necessary traffic control, signage, barricades, etc., in compliance with City, County, and State traffic control regulations.

### Repair Materials:

All materials used in the repair of the cut will be the responsibility of the Contractor.

Spoil from the cut shall be disposed of at the Biosolids Facility on Lake Avenue for materials that were removed from cuts that occurred after normal working hours. If access is not established to these sites then spoils can be dumped at the Maintenance Department yards if authorized by Utility personnel.

### Statements of Conditions

Equipment and operation therefore shall comply with all Federal, State, County, and City regulations governing such equipment and its operation. The contractor shall not proceed with any work contrary to law. All equipment shall be in good mechanical condition when reporting for work. The Utility will not pay for any lost time due to mechanical defects or time spent performing necessary repairs. The contractor shall report all breakdowns immediately to the Utility supervisor.

The City of Fort Wayne reserves the right to make a rigid inspection as to mechanical and safety features of any and all construction equipment dispatched to work sites at any time during the period of the contract. Such inspections shall in no way relieve the contractor of the responsibility to furnish equipment in compliance with all requirements of the specifications. All equipment which, in the opinion of the City of Fort Wayne, is in poor mechanical condition or otherwise does not comply with these specifications, will be rejected and shall not be used on any Utility project until repaired or replaced.

Equipment and its operation shall be subject to supervision by Utility supervisory personnel as to the work to be performed. The Utility will not instruct the operation of equipment in any way contrary to law or good equipment practice. The contractor and/or the operator shall be solely responsible for any and all damage to equipment while operating under this specification.

The contractor is responsible for providing the Utility, in writing, the names and telephone numbers (for day and night contact) which may be used to call regarding contract equipment.

Payment will be based on the Square Foot bid received by the Board of Works. The designated work site shall be specified by the Utility. Payments will be made to the contractor within forty-five (45) days following receipt of invoice. Invoices are to be mailed directly to contracting department of the Utility.

### Contract Compliance

The contractor shall comply with requirements of the Fort Wayne Contract Compliance Department in regard to EBE Goals, and other documentation, if requested.

### Award

Award of work shall be at the sole discretion of the Utility, with consideration for the following factors being part of the determination:

1. Lowest rates per Sq Ft price quote; based on 50 sq ft and smaller, 51 to 100 sq ft, and 101 sq ft or larger
2. Availability when called. If contact cannot be made with the contractor, or if contractor does not have the necessary equipment and manpower available to perform this work within the time requested, further calling to the contractor for the specific job will not be mandatory.
3. Quality of equipment and efficiency of operation based on previous work observations by the Utility personnel:
4. In cases where bids are equal, the contractors will be rotated.

This agreement may be terminated in part or in whole, if any work performed is not in accordance with the standards established by the Utility.

The contractor hereby agrees that when notified by the Utility, the contractor will supply the equipment, manpower, and materials as necessary to complete work based on Square ft of repair at the price indicated in their quote, hereto and made a part hereof. And all work will be performed to comply with Transportation Engineering's Standards dated 8-27-15.

Roboco, Inc / Skip Chambers  
 Contractor's Name

P.O. Box 902, FW, IN, 46899  
 Contractor's Address

Alfred (Skip) Chambers - Vice President  
 Contractor Name's/ Title (please print)

Alfred Chambers  
 Contractor's Signature

11/29/2023  
 (Date)

**Contractor to complete below Exhibits:**

**EXHIBIT A - CONTRACTOR CONTACT INFORMATION**

<u>Authorized Contact</u>	<u>Cell Phone</u>	<u>Work Phone</u>	<u>Home Phone</u>	<u>Emergency Contact Number</u>
Skip Chambers	910-410-6120	511	511	240-312-1051



**Robbco, Inc.**

**01/01/2023**

## **Corporate Policy & Procedure**

**Policy: Drug and Alcohol-Free Workplace**

**Scope: All Employees of Robbco, Inc.**

### **Purpose:**

The purpose of this policy is to inform all employees of Robbco, Inc. including owners, officers, employees, contractors, subcontractors, or agents performing any duties for Robbco, Inc. of our guidelines for maintaining a work environment that is free from drugs and alcohol.

### **Policy:**

Robbco, Inc. is an organization where responsibilities are governed by policies, including penalties for violations of standards as stated in the Employee Policy Guidelines.

Robbco, Inc. is committed to providing a safe, drug-free workplace and to protect the interests of our employees and our clients. All prospective Robbco, Inc. employees will be subject to initial drug testing, random drug testing due to an accident and/or injury. Robbco, Inc. policy prohibits anyone from using, possessing, selling, distributing, manufacturing, purchasing, or being under the influence of alcohol, illegal drugs, intoxicants, or controlled substances while performing work for Robbco, Inc. while on Robbco, Inc. premises or on any company job site, including operating any vehicles leased or owned by Robbco, Inc.

If at any time you suspect any of your co-workers to be under the influence of any drug while at work, you are required to immediately report your suspicion to your supervisor and the person suspected will be immediately notified and sent to a licensed laboratory for testing. Suspicion may include but is not limited to the following behaviors: blood shot eyes, smelling of alcohol or other illegal substances, slurring of speech, inability to function properly, etc.

### **Procedures:**

1. Robbco, Inc. will impose disciplinary action up to and including termination of employment for any positive drug and/or alcohol testing or refusal of drug and/or alcohol testing.
2. Any felony conviction relating to a controlled substance will be cause for Robbco, Inc. to impose termination of employment due to strict state regulations.
3. Any Robbco, Inc. employee who is injured, caused accidental injury or harm, or involved in a vehicular accident in a personal Robbco, Inc. owned vehicle, while on duty, will be

required to immediately submit to drug and/or alcohol testing following the report of an accident.

4. For the purpose of this policy, the use of prescription drugs by a person for whom they have not been prescribed or for use not consistent with the prescription is prohibited.
5. Any employee who is using prescription or over-the-counter drugs that may impair the employee's ability to safely perform their job, or affect the safety or well being of others, must notify a manager of such use immediately before or resuming work.
6. This policy will not be construed to prohibit the moderate consumption of alcohol during social or business functions sponsored by Robbco, Inc. where alcohol is served, or while entertaining stakeholders and/or individuals of Robbco, Inc.

CERTIFICATE IN LIEU OF FINANCIAL STATEMENT

I, Alfred Chambers, the Vice President  
NAME POSITION  
of Robco, Inc.

HEREBY CERTIFY THAT:

1. The Financial Statement of said Company, dated the 31 day of December, 2023 now on file in the office of the Board of Public Works of the City of Fort Wayne, Indiana, made a part hereof, is a true and correct statement, and, accurately reflects the financial condition of said Company, as of the date hereof; and,
2. I am familiar with the books of said Company, showing its financial condition and am authorized to make this certificate on its behalf.

DATE: 11/29/23

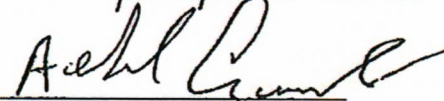
  
SIGNATORY

Alfred Chambers  
PRINTED NAME OF SIGNATORY

CERTIFICATE IN LIEU OF DRUG TESTING PROGRAM

I, Alfred Chambers, the Vice President  
NAME POSITION  
of Robeco, Inc.  
COMPANY

HEREBY CERTIFY THAT:

1. A copy of our Drug Testing Program of said Company, dated the 29 day of Nov.,  
2023, now on file in the office of the Board of Public Works of the City of Fort Wayne, Indiana.

DATE: 11/29/23

Alfred Chambers  
SIGNATORY

Alfred Chambers  
PRINTED NAME OF SIGNATORY



TRANSPORTATION  
ENGINEERING  
STANDARD DETAILS

# ARTERIAL / COLLECTOR FULL DEPTH PAVEMENT PATCH

## FULL DEPTH PAVEMENT OPTION

NOT TO SCALE

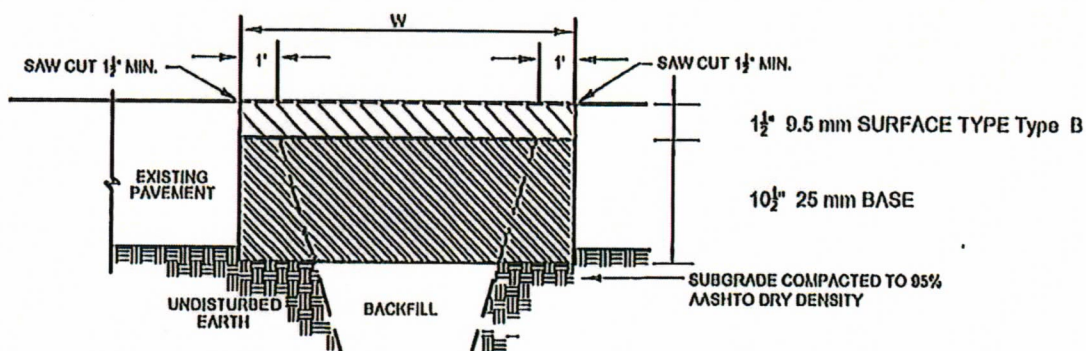

**NOTES**

- \* IF EXISTING PAVEMENT IS THICKER THAN 12", AN ADDITIONAL LIFT OF HMA BASE, 25 mm IS TO BE USED TO MATCH THE EXISTING PAVEMENT THICKNESS.

1. SAW CUTS SHALL PROVIDE A VERTICAL, NEAT, AND UNIFORM EDGE.
2. ALL MATERIALS SHALL COMPLY WITH SPECIFICATIONS AS REQUIRED BY THE FORT WAYNE TRANSPORTATION ENGINEERING DEPARTMENT.
3. THE EXISTING VERTICAL EDGE OF PAVEMENT IS TO BE TACK COATED PRIOR TO THE PLACEMENT OF NEW ASPHALT. TACK COAT IS TO BE APPLIED BETWEEN COURSES OF NEW ASPHALT PAVEMENT AS REQUIRED BY THE FORT WAYNE TRANSPORTATION ENGINEERING DEPARTMENT.
4. THE NEW SURFACE PAVEMENT GRADE SHALL MATCH THE EXISTING SURFACE PAVEMENT GRADE.
5. ASPHALT BASE DEPTH SHALL BE COMPACTED IN LIFTS NO GREATER THAN 6".
6. REPLACE ALL APPROPRIATE PAVEMENT MARKINGS.
7. WHEN THE PATCH EXCEEDS A LENGTH OF 30' OR WHEN THE PATCH EXCEEDS A WIDTH OF 6', LANE - WIDE MILLING WILL BE REQUIRED TO THE DEPTH OF THE SURFACE OVERLAY.

DATE: 4/28/16

NOT TO SCALE

APPROVED BY: M.T.

SHEET NO:SECTIONS



TRANSPORTATION  
ENGINEERING  
STANDARD DETAILS

# LOCAL / RESIDENTIAL FULL DEPTH PAVEMENT PATCH

## FULL DEPTH PAVEMENT OPTION

NOT TO SCALE

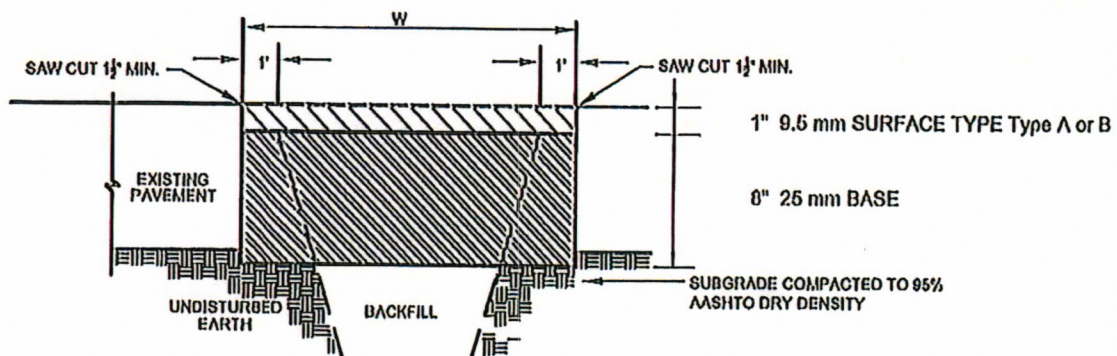

**NOTES**

- IF EXISTING PAVEMENT IS THICKER THAN 8", AN ADDITIONAL LIFT OF HMA BASE, 25 mm IS TO BE USED TO MATCH THE EXISTING PAVEMENT THICKNESS.

1. SAW CUTS SHALL PROVIDE A VERTICAL, NEAT, AND UNIFORM EDGE.
2. ALL MATERIALS SHALL COMPLY WITH SPECIFICATIONS AS REQUIRED BY THE FORT WAYNE TRANSPORTATION ENGINEERING DEPARTMENT.
3. THE EXISTING VERTICAL EDGE OF PAVEMENT IS TO BE TACK COATED PRIOR TO THE PLACEMENT OF NEW ASPHALT. TACK COAT IS TO BE APPLIED BETWEEN COURSES OF NEW ASPHALT PAVEMENT AS REQUIRED BY THE FORT WAYNE TRANSPORTATION ENGINEERING DEPARTMENT.
4. THE NEW SURFACE PAVEMENT GRADE SHALL MATCH THE EXISTING SURFACE PAVEMENT GRADE.
5. ASPHALT BASE DEPTH SHALL BE COMPACTED IN LIFTS NO GREATER THAN 4".
6. REPLACE ALL APPROPRIATE PAVEMENT MARKINGS.

DATE: 9/17/15

NOT TO SCALE

APPROVED BY: M.T.

SHEET NO:SECTIONS

# Interoffice Memo

Date: January 9, 2024  
To: Common Council Members  
From: Matt Land, City Utilities, Deputy Director of Utilities Chief Operations Officer  
**RE: Annual On-Call Asphalt Cut Repair Services**

Members of City Council:

Approval requested for Professional Services Agreement between the City of Fort Wayne and Robbco, Inc. for Annual On-Call Asphalt Cut Repair Services.

Compensation for services performed shall be \$405,000.00 for 2024.

CC: BOW  
Justin Brugger  
Kumar Menon  
Jill Helfrich  
Chrono  
File

**BILL NO. S-24-01-06**

**REPORT OF COMMITTEE ON CITY UTILITIES**

**January 16, 2024**

***Paul Ensley Chair***







***Russ Jehl Co-Chair***

***All Council Members***

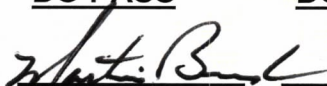
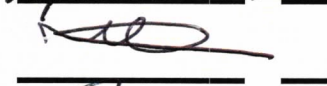
An Ordinance approving Services Agreement – 2024 Annual On-Call Asphalt Cut Repair Services between Robbco, Inc. and the City of Fort Wayne, Indiana, by and through its Division of City Utilities

*Involving a total cost not to exceed \$405,000.00*

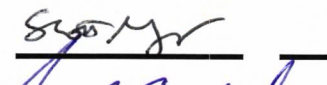
**COMMITTEE ON CITY UTILITIES HAVE HAD SAID Ordinance under consideration and beg leave to report back to the Common Council that said Ordinance**

<u>COUNCIL MEMBER</u>	<u>DO PASS</u>	<u>DO NOT PASS</u>	<u>ABSTAIN</u>
<u>BENDER</u>			
<u>CHAMBERS</u>			
<u>ENSLEY</u>			
<u>FREISTROFFER</u>			
<u>HARTMAN</u>			
<u>JEHL</u>			
<u>MYERS</u>			
<u>PADDOCK</u>			
<u>TUCKER</u>			

**STACY REED  
DEPUTY CITY CLERK**

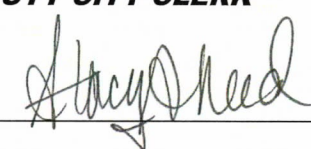

Public Hearing Date: N/A

Read the first time in full and on motion by Councilperson Ensley.

Read the second time by title and referred to the City Utilities Committee.

Read the third time in full and on motion by Councilperson Ensley, placed on passage by the following vote:

<u>TOTAL VOTES</u>	<u>AYES</u>	<u>NAYS</u>	<u>ABSTAINED</u>	<u>ABSENT</u>
BENDER	<input checked="" type="checkbox"/>	<input type="checkbox"/>	<input type="checkbox"/>	<input type="checkbox"/>
CHAMBERS	<input checked="" type="checkbox"/>	<input type="checkbox"/>	<input type="checkbox"/>	<input type="checkbox"/>
ENSLEY	<input checked="" type="checkbox"/>	<input type="checkbox"/>	<input type="checkbox"/>	<input type="checkbox"/>
FREISTROFFER	<input checked="" type="checkbox"/>	<input type="checkbox"/>	<input type="checkbox"/>	<input type="checkbox"/>
HARTMAN	<input checked="" type="checkbox"/>	<input type="checkbox"/>	<input type="checkbox"/>	<input type="checkbox"/>
JEHL	<input checked="" type="checkbox"/>	<input type="checkbox"/>	<input type="checkbox"/>	<input type="checkbox"/>
MYERS	<input type="checkbox"/>	<input type="checkbox"/>	<input type="checkbox"/>	<input checked="" type="checkbox"/>
PADDOCK	<input checked="" type="checkbox"/>	<input type="checkbox"/>	<input type="checkbox"/>	<input type="checkbox"/>
TUCKER	<input checked="" type="checkbox"/>	<input type="checkbox"/>	<input type="checkbox"/>	<input type="checkbox"/>

*Stacy Reed*

DATED: January 23, 2024

STACY REED, DEPUTY CITY CLERK

Passed and adopted by the Common Council of the City of Fort Wayne, Indiana, as

Special Resolution No. S-24-01-06 on the 23rd day of January, 2024

ATTEST:

*Stacy Reed*

STACY REED  
DEPUTY CITY CLERK

*Thomas J. Freistoffer*

PRESIDING OFFICER

Presented by me to the Mayor of the City of Fort Wayne, Indiana, on the 24th of January 2024, at the hour of 10:45 o'clock A.M. E.S.T.

*Stacy Reed*

STACY REED, DEPUTY CITY CLERK

Approved and signed by me this 30<sup>th</sup> day of JANUARY 2024, at the hour of 9:00 o'clock AM E. S.T.

*Thomas C. Henry*  
THOMAS C. HENRY, MAYOR

