

1
2
3
4
5
6
7
8
9
10
11
12
13
14
15
16
17
18
19
20
21
22
23
24
25
26
27
28
29
30

BILL NO. S-15-12-04-(AS AMENDED)

SPECIAL ORDINANCE NO. S-107-15

AN ORDINANCE approving FORT WAYNE CONSTRUCTION TRADES DEVELOPMENT CONTRACTUAL AGREEMENT - ANTHIS CAREER CENTER - ANNUAL CONTRACT FOR CUT RESTORATIONS - #WMS52268013-5364 between FORT WAYNE COMMUNITY SCHOOLS ANTHIS CAREER CENTER and the City of Fort Wayne, Indiana, in connection with the Board of Public Works.

NOW, THEREFORE, BE IT ORDAINED BY THE COMMON COUNCIL OF THE CITY OF FORT WAYNE, INDIANA:

SECTION 1. That the FORT WAYNE CONSTRUCTION TRADES DEVELOPMENT CONTRACTUAL AGREEMENT - ANTHIS CAREER CENTER - ANNUAL CONTRACT FOR CUT RESTORATIONS - #WMS52268013-5364 by and between FORT WAYNE COMMUNITY SCHOOLS ANTHIS CAREER CENTER and the City of Fort Wayne, Indiana, in connection with the Board of Public Works, is hereby ratified, and affirmed and approved in all respects, respectfully for:

All labor, insurance, material, equipment, tools, power, transportation, miscellaneous equipment, etc., necessary for repair of concrete areas and Grass and Soil cuts made when repairing main, services and other water distribution system piping:

involving a total cost not to exceed TWO HUNDRED THOUSAND AND 00/100 DOLLARS - (\$200,000.00). A copy of said Contract is on file with the Office of the City Clerk and made available for public inspection, according to law.

1
2
3
4
5
6
7
8
9
10
11
12
13
14
15
16
17
18
19
20
21
22
23
24
25
26
27
28
29
30

SECTION 2. That this Ordinance shall be in full force and effect from and after its passage and any and all necessary approval by the Mayor.



Council Member

APPROVED AS TO FORM AND LEGALITY



Carol Helton, City Attorney

1
2 **BILL NO. S-15-12-04** AS AMENDED

3 SPECIAL ORDINANCE NO. S-_____

4 AN ORDINANCE approving FORT WAYNE
5 CONSTRUCTION TRADES DEVELOPMENT
6 CONTRACTUAL AGREEMENT - ANTHIS
7 CAREER CENTER - ANNUAL CONTRACT FOR
8 CUT RESTORATIONS - #WMS52268013-5364
9 between FORT WAYNE COMMUNITY SCHOOLS
10 ANTHIS CAREER CENTER and the City of Fort
11 Wayne, Indiana, in connection with the Board of
12 Public Works.

13 **NOW, THEREFORE, BE IT ORDAINED BY THE COMMON**
14 **COUNCIL OF THE CITY OF FORT WAYNE, INDIANA:**

15 **SECTION 1.** That the FORT WAYNE CONSTRUCTION
16 TRADES DEVELOPMENT CONTRACTUAL AGREEMENT - ANTHIS
17 CAREER CENTER - ANNUAL CONTRACT FOR CUT RESTORATIONS -
18 #WMS52268013-5364 by and between FORT WAYNE COMMUNITY
19 SCHOOLS ANTHIS CAREER CENTER and the City of Fort Wayne, Indiana,
20 in connection with the Board of Public Works, is hereby ratified, and affirmed
21 and approved in all respects, respectfully for:

22 All labor, insurance, material, equipment, tools, power,
23 transportation, miscellaneous equipment, etc., necessary for
24 repair of concrete areas and Grass and Soil cuts made
25 when repairing main, services and other water distribution
26 system piping:

27 involving a total cost ^{not} ~~of~~ to exceed TWO HUNDRED THOUSAND AND 00/100
28 DOLLARS - (\$200,000.00*). A copy of said Contract is on file with the Office
29 of the City Clerk and made available for public inspection, according to law.
30

1
2 **BILL NO. S-15-12-04**

3 SPECIAL ORDINANCE NO. S-_____

4 AN ORDINANCE approving FORT WAYNE
5 CONSTRUCTION TRADES DEVELOPMENT
6 CONTRACTUAL AGREEMENT - ANTHIS
7 CAREER CENTER - ANNUAL CONTRACT FOR
8 CUT RESTORATIONS - #WMS52268013-5364
9 between FORT WAYNE COMMUNITY SCHOOLS
10 ANTHIS CAREER CENTER and the City of Fort
11 Wayne, Indiana, in connection with the Board of
12 Public Works.

13 **NOW, THEREFORE, BE IT ORDAINED BY THE COMMON**
14 **COUNCIL OF THE CITY OF FORT WAYNE, INDIANA:**

15 **SECTION 1.** That the FORT WAYNE CONSTRUCTION
16 TRADES DEVELOPMENT CONTRACTUAL AGREEMENT - ANTHIS
17 CAREER CENTER - ANNUAL CONTRACT FOR CUT RESTORATIONS -
18 #WMS52268013-5364 by and between FORT WAYNE COMMUNITY
19 SCHOOLS ANTHIS CAREER CENTER and the City of Fort Wayne, Indiana,
20 in connection with the Board of Public Works, is hereby ratified, and affirmed
21 and approved in all respects, respectfully for:

22 All labor, insurance, material, equipment, tools, power,
23 transportation, miscellaneous equipment, etc., necessary for
24 repair of concrete areas and Grass and Soil cuts made
25 when repairing main, services and other water distribution
26 system piping:

27 involving a total cost ^{not} of ~~to~~ exceed TWO HUNDRED THOUSAND AND 00/100
28 DOLLARS - (\$200,000.00~~*~~). A copy of said Contract is on file with the Office
29 of the City Clerk and made available for public inspection, according to law.
30

1
2
3
4
5
6
7
8
9
10
11
12
13
14
15
16
17
18
19
20
21
22
23
24
25
26
27
28
29
30

SECTION 2. That this Ordinance shall be in full force and effect from and after its passage and any and all necessary approval by the Mayor.



Council Member

APPROVED AS TO FORM AND LEGALITY



Carol Helton, City Attorney

October 1, 2015

Fort Wayne Construction Trades Development
Contractual Agreement
with
The City of Fort Wayne Water Maintenance
2016

Fort Wayne Construction Trades proposes the following items for the repair and restoration work that the City Water Maintenance is requesting. With the partnership of employment of Fort Wayne Community Schools, Fort Wayne Construction Trades students will begin restoration work as soon as the ground thaws, and will continue working until or through December 2016. A crew will begin the work under general instructional supervision of Chris Roberts and site supervision of Michael Wright and Kanez Omar. There will be a group of five High School Junior's hired and one senior re-hired from the Anthis Career Center. All students will be subject to the general hiring guidelines and employment regulations of Fort Wayne Community Schools. The restoration staff will be held to all safety guidelines specified by The City Fort Wayne Water Maintenance. The general hourly pay rate of the entire crew of five students, one dirt crew foreman, one concrete foreman, one daily operations supervisor, and one general instructor is \$195.00. During the 2016-2017 school year the staff will be supervised indirectly by Chris Roberts as an unpaid position. At the conclusion of the 2016-2017 school year the instructor will join the team of construction trades students on site. This pay scale is subject to change due to weekly crew changes and personnel daily schedules but will not exceed the \$195.00 per hour rate. The amount per hour will only exceed the rate listed above due to overtime pay on a bi-weekly basis, at a rate of time and a half for each employee.

All materials necessary for job completion will be charged to City Water Maintenance over and beyond the general hourly rate. The items included as part of material fees would include concrete, rebar, expansion, curing, form release, gasoline, hand tools, concrete forms and minor equipment repairs. All receipts and invoices will be returned to City Water Maintenance for their records.

Construction Trades Instructor

Date 10/1/15

Construction Trades Project Manager

Date 10/01/15

Deputy Director City Utilities Capital Assets

Date 10/8/15

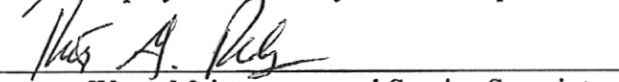

Water Maintenance and Service Superintendent

Date 10/11/15

Approval of Service Agreement between the City of Fort Wayne and Anthis Career Center to perform Cut restorations of Concrete and Soil for City Utilities.

BOARD OF PUBLIC WORKS

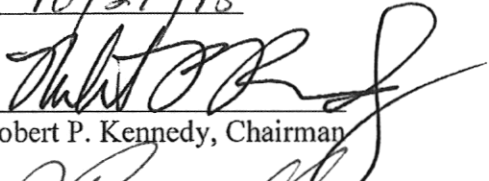
Date: 10/21/15

BY: 
Robert P. Kennedy, Chairman

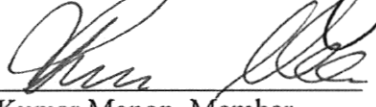
BY: 
Kumar Menon, Member

BY: Mike Avila
Mike Avila, Member

ATTEST: 
Lyndsey Richards, Clerk



SERVICE AGREEMENT: _____ #WMS52268013-5364

SUPPLIER NAME Fort Wayne Community Schools Anthis Career Center		CITY DEPARTMENT Water Maintenance and Service	
STREET ADDRESS 1200 S Barr Street		STREET ADDRESS 415 East Wallace Street	
CITY, STATE, ZIP CODE Fort Wayne Indiana 46802		CITY, STATE, ZIP CODE Fort Wayne Indiana 46802	
ATTENTION Christopher Roberts		INVOICE ADDRESS 415 East Wallace Street	
TELEPHONE 260-425-7200	FAX	CITY, STATE, ZIP CODE Fort Wayne Indiana 46802	
REMIT-TO ADDRESS 1200 S Barr Street		ATTENTION Matt Limpert	
CITY, STATE, ZIP CODE Fort Wayne Indiana 46802		TELEPHONE 260-427-2484	FAX 260-427-1282

Service Description

Rates

Repair of concrete areas and Grass and Soil cuts made when repairing main, services and other water distribution system piping. Per Transportation Engineering Standard details for Concrete Pavement Patch.	Per attached Contract
Aggregate Price	Not to exceed \$295,000

with exceed \$200,000
put that language back in. Except for amount.

The following Attachments are part of this Agreement:

Agreement with Anthis Career Center

SERVICE ADDRESS To be assigned by Water Maintenance Personnel on an as needed basis.
CITY, STATE, ZIP CODE
AGREEMENT START DATE January 1, 2016
AGREEMENT END DATE December 31, 2016

This Agreement is entered into between Supplier and the City as of November 13, 2015. The additional terms and conditions on the reverse side hereof are part of this Agreement. Capitalized terms on this page are used as defined terms when the context so requires. The City may extend the Contract at its option, for an equivalent period, by written notice to the Supplier not less than thirty days prior to the expiration date.

SUPPLIER:

City of Fort Wayne

By (Signature):	By (Signature):
Printed Name:	Printed Name:
Title:	Title:
Date:	Date:



TRANSPORTATION
ENGINEERING
STANDARD DETAILS

ARTERIAL / COLLECTOR FULL DEPTH PAVEMENT PATCH

FULL DEPTH PAVEMENT OPTION

NOT TO SCALE

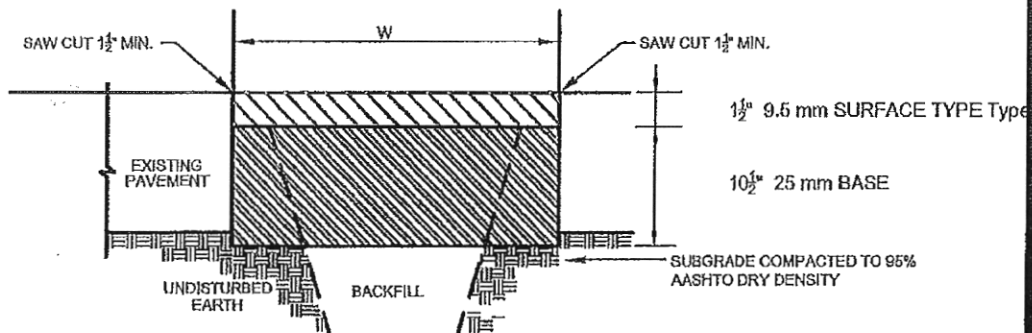

NOTES

- * IF EXISTING PAVEMENT IS THICKER THAN 12", AN ADDITIONAL LIFT OF HMA BASE, 25 mm IS TO BE USED TO MATCH THE EXISTING PAVEMENT THICKNESS.

1. SAW CUTS SHALL PROVIDE A VERTICAL, NEAT, AND UNIFORM EDGE.
2. ALL MATERIALS SHALL COMPLY WITH SPECIFICATIONS AS REQUIRED BY THE FORT WAYNE ENGINEERING DEPARTMENT.
3. THE EXISTING VERTICAL EDGE OF PAVEMENT IS TO BE TACK COATED PRIOR TO THE PLACEMENT OF NEW ASPHALT. TACK COAT IS TO BE APPLIED AS SPECIFIED IN THE CITY OF FORT WAYNE SPECIFICATIONS.
4. THE NEW SURFACE PAVEMENT GRADE SHALL MATCH THE EXISTING SURFACE PAVEMENT GRADE.
5. ASPHALT BASE DEPTH SHALL BE COMPACTED IN LIFTS NO GREATER THAN 4".
6. REPLACE ALL APPROPRIATE PAVEMENT MARKINGS.

DATE: 8/27/15

NOT TO SCALE

APPROVED BY: M.T.

SHEET NO:SECTIONS



LOCAL / RESIDENTIAL FULL DEPTH PAVEMENT PATCH

FULL DEPTH PAVEMENT OPTION

NOT TO SCALE

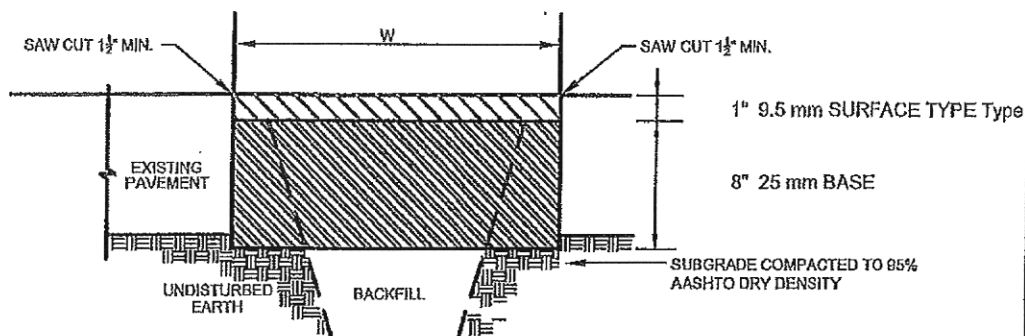

NOTES

- * IF EXISTING PAVEMENT IS THICKER THAN 8", AN ADDITIONAL LIFT OF HMA BASE, 25 mm IS TO BE USED TO MATCH THE EXISTING PAVEMENT THICKNESS.
1. SAW CUTS SHALL PROVIDE A VERTICAL, NEAT, AND UNIFORM EDGE.
 2. ALL MATERIALS SHALL COMPLY WITH SPECIFICATIONS AS REQUIRED BY THE FORT WAYNE ENGINEERING DEPARTMENT.
 3. THE EXISTING VERTICAL EDGE OF PAVEMENT IS TO BE TACK COATED PRIOR TO THE PLACEMENT OF NEW ASPHALT, TACK COAT IS TO BE APPLIED AS SPECIFIED IN THE CITY OF FORT WAYNE SPECIFICATIONS.
 4. THE NEW SURFACE PAVEMENT GRADE SHALL MATCH THE EXISTING SURFACE PAVEMENT GRADE.
 5. ASPHALT BASE DEPTH SHALL BE COMPACTED IN LIFTS NO GREATER THAN 4".
 6. REPLACE ALL APPROPRIATE PAVEMENT MARKINGS.



TRANSPORTATION
ENGINEERING
STANDARD DETAILS

ARTERIAL / COLLECTOR CONCRETE PAVEMENT PATCH

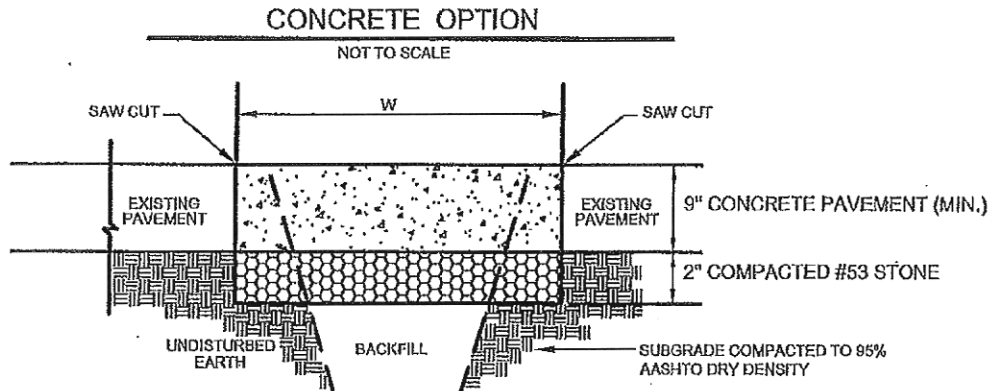

- NOTES**
1. SAW CUTS SHALL PROVIDE A VERTICAL, CLEAN, AND UNIFORM EDGE.
 2. ALL MATERIALS SHALL COMPLY WITH SPECIFICATIONS AS REQUIRED BY THE FORT WAYNE TRANSPORTATION ENGINEERING DEPARTMENT.
 3. CONCRETE SURFACE SHALL BE BROOM FINISH AT RIGHT ANGLES TO TRAFFIC FLOW.
 4. CONCRETE PATCHING ON RESIDENTIAL/LOCAL STREETS SHALL CONSIST OF PLACING CLASS A, 4000 PSI, SIX (6) BAG MIX, 564 LBS. OF PORTLAND CEMENT PER CUBIC YARD AND TO A NINE INCH (9") MINIMUM DEPTH WITH CONTRACTION JOINTS TO MATCH EXISTING JOINT PATTERN. EXCAVATE TO PLACE A TWO INCH (2") COURSE OF COARSE AGGREGATE FOR BASE, NO. 53.

NOTE: A MEDIUM-RANGE, WATER-REDUCING ADMIXTURE MAY BE USED PROVIDING DOSAGE RATES DO NOT EXCEED 9 FL. OZ. PER 100 LBS. OF CEMENTITIOUS MATERIAL SHALL BE DEFINED AS TYPE I PORTLAND CEMENT. ALL OTHER POZZOLANIC MATERIALS SUCH AS FLY ASH, SILICA FUME AND GGBFS (GROUND-GRANULATED BLAST FURNACE SLAG) SHALL NOT BE USED.
 5. CONCRETE SLUMPS SHALL NOT EXCEED 4". A MINIMUM OF 550 PSI FLEXURAL STRENGTH MUST BE ACHIEVED PRIOR TO ALLOWING ROADWAY TO BE OPENED TO ANY VEHICULAR TRAFFIC.
 6. THE CONCRETE PATCH SHALL BE ANCHORED TO THE EXISTING CONCRETE PAVEMENT ALONG THE LONGITUDINAL JOINT USING #5 DEFORMED REBAR SPACED 3'-0" ON CENTER AND ALONG THE TRANSVERSE JOINT USING #5 DEFORMED REBAR SPACED 2'-0" ON CENTER.
 7. THE NEW SURFACE PAVEMENT GRADE SHALL MATCH THE EXISTING SURFACE PAVEMENT GRADE UNLESS OTHERWISE DIRECTED BY CITY REPRESENTATIVE.
 8. ALL CONCRETE PATCHES SHALL BE CONSTRUCTED TO THE FULL SLAB OR HALF SLAB CONCRETE JOINTS. JOINT TO JOINT, CENTERLINE TO BACK OF CURB.

DATE: 9/2/15

NOT TO SCALE

APPROVED BY: M.T. SHEET NO:SECTIONS



TRANSPORTATION
ENGINEERING
STANDARD DETAILS

LOCAL / RESIDENTIAL CONCRETE PAVEMENT PATCH

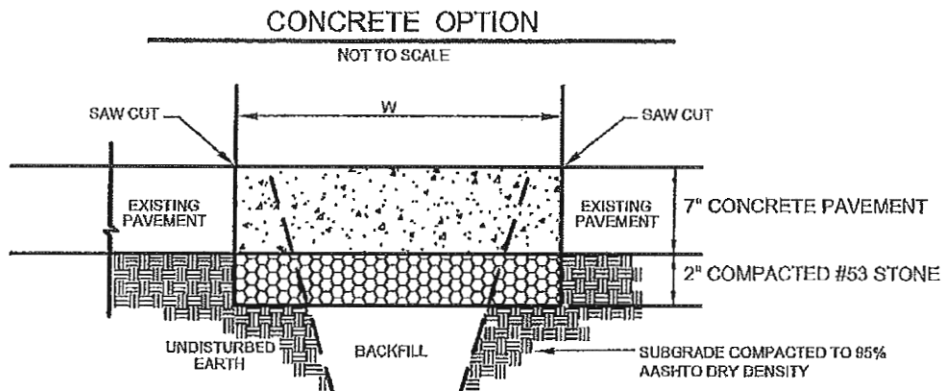

- NOTES.**
1. SAW CUTS SHALL PROVIDE A VERTICAL, CLEAN, AND UNIFORM EDGE.
 2. ALL MATERIALS SHALL COMPLY WITH SPECIFICATIONS AS REQUIRED BY THE FORT WAYNE TRANSPORTATION ENGINEERING DEPARTMENT.
 3. CONCRETE SURFACE SHALL BE BROOM FINISH AT RIGHT ANGLES TO TRAFFIC FLOW.
 4. CONCRETE PATCHING ON RESIDENTIAL/LOCAL STREETS SHALL CONSIST OF PLACING CLASS A, 4000 PSI, SIX (6) BAG MIX, 504 LBS. OF PORTLAND CEMENT PER CUBIC YARD AND TO A SEVEN INCH (7") DEPTH WITH CONTRACTION JOINTS TO MATCH EXISTING JOINT PATTERN. EXCAVATE TO PLACE A TWO INCH (2") COURSE OF COARSE AGGREGATE FOR BASE, NO. 53.

NOTE: A MEDIUM-RANGE, WATER-REDUCING ADMIXTURE MAY BE USED PROVIDING DOSAGE RATES DO NOT EXCEED 9 FL. OZ. PER 100 LBS. OF CEMENTITIOUS MATERIAL SHALL BE DEFINED AS TYPE I PORTLAND CEMENT. ALL OTHER POZZOLANIC MATERIALS SUCH AS FLY ASH, SILICA FUME AND GGBFS (GROUND-GRANULATED BLAST FURNACE SLAG) SHALL NOT BE USED.

5. CONCRETE SLUMPS SHALL NOT EXCEED 4". A MINIMUM OF 650 PSI FLEXURAL STRENGTH MUST BE ACHIEVED PRIOR TO ALLOWING ROADWAY TO BE OPENED TO ANY VEHICULAR TRAFFIC.
6. THE CONCRETE PATCH SHALL BE ANCHORED TO THE EXISTING CONCRETE PAVEMENT ALONG THE LONGITUDINAL JOINT USING #4 DEFORMED REBAR SPACED 3'-0" ON CENTER AND ALONG THE TRANSVERSE JOINT USING #4 DEFORMED REBAR SPACED 2'-0" ON CENTER.
7. THE NEW SURFACE PAVEMENT GRADE SHALL MATCH THE EXISTING SURFACE PAVEMENT GRADE UNLESS OTHERWISE DIRECTED BY CITY REPRESENTATIVE.
8. ALL CONCRETE PATCHES SHALL BE CONSTRUCTED TO THE FULL SLAB OR HALF SLAB CONCRETE JOINTS. JOINT TO JOINT, CENTERLINE TO BACK OF CURB.

DATE: 9/2/15

NOT TO SCALE

APPROVED BY: M.T.

SHEET NO:SECTIONS



LOCAL / RESIDENTIAL CONCRETE PAVEMENT PATCH

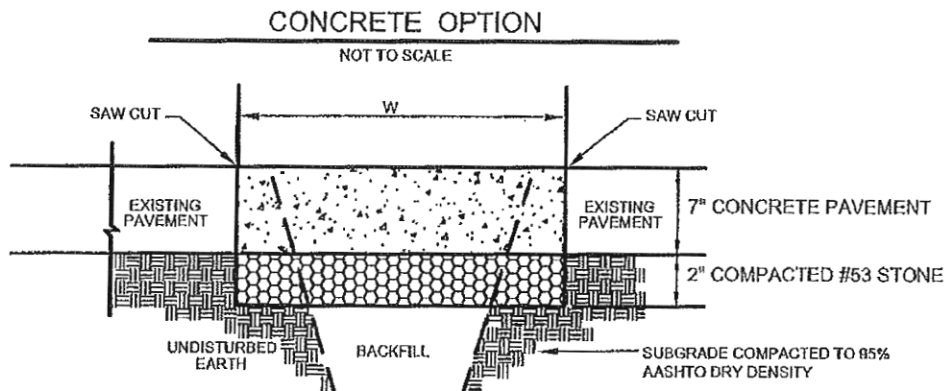

- NOTES.**
1. SAW CUTS SHALL PROVIDE A VERTICAL, CLEAN, AND UNIFORM EDGE.
 2. ALL MATERIALS SHALL COMPLY WITH SPECIFICATIONS AS REQUIRED BY THE FORT WAYNE TRANSPORTATION ENGINEERING DEPARTMENT.
 3. CONCRETE SURFACE SHALL BE BROOM FINISH AT RIGHT ANGLES TO TRAFFIC FLOW.
 4. CONCRETE PATCHING ON RESIDENTIAL/LOCAL STREETS SHALL CONSIST OF PLACING CLASS A, 4000 PSI, SIX (6) BAG MIX, 564 LBS. OF PORTLAND CEMENT PER CUBIC YARD AND TO A SEVEN INCH (7") DEPTH WITH CONTRACTION JOINTS TO MATCH EXISTING JOINT PATTERN. EXCAVATE TO PLACE A TWO INCH (2") COURSE OF COARSE AGGREGATE FOR BASE, NO. 53.

NOTE: A MEDIUM-RANGE, WATER-REDUCING ADMIXTURE MAY BE USED PROVIDING DOSAGE RATES DO NOT EXCEED 9 FL. OZ. PER 100 LBS. OF CEMENTITIOUS MATERIAL SHALL BE DEFINED AS TYPE I PORTLAND CEMENT. ALL OTHER POZZOLANIC MATERIALS SUCH AS FLY ASH, SILICA FUME AND GGBFS (GROUND-GRANULATED BLAST FURNACE SLAG) SHALL NOT BE USED.
 5. CONCRETE SLUMPS SHALL NOT EXCEED 4". A MINIMUM OF 650 PSI FLEXURAL STRENGTH MUST BE ACHIEVED PRIOR TO ALLOWING ROADWAY TO BE OPENED TO ANY VEHICULAR TRAFFIC.
 6. THE CONCRETE PATCH SHALL BE ANCHORED TO THE EXISTING CONCRETE PAVEMENT ALONG THE LONGITUDINAL JOINT USING #4 DEFORMED REBAR SPACED 3'-0" ON CENTER AND ALONG THE TRANSVERSE JOINT USING #4 DEFORMED REBAR SPACED 2'-0" ON CENTER.
 7. THE NEW SURFACE PAVEMENT GRADE SHALL MATCH THE EXISTING SURFACE PAVEMENT GRADE UNLESS OTHERWISE DIRECTED BY CITY REPRESENTATIVE.
 8. ALL CONCRETE PATCHES SHALL BE CONSTRUCTED TO THE FULL SLAB OR HALF SLAB CONCRETE JOINTS. JOINT TO JOINT, CENTERLINE TO BACK OF CURB.

DATE: 9/2/15

NOT TO SCALE

APPROVED BY: M.T.

SHEET NO:SECTIONS



ARTERIAL / COLLECTOR CONCRETE PAVEMENT PATCH

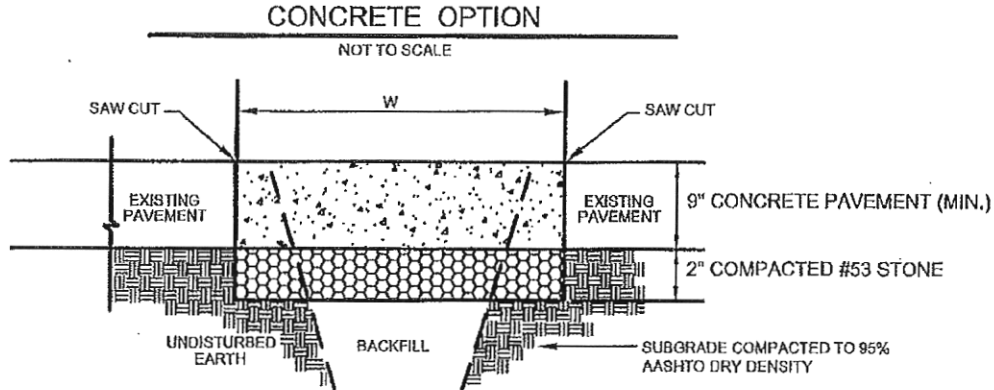

NOTES

1. SAW CUTS SHALL PROVIDE A VERTICAL, CLEAN, AND UNIFORM EDGE.
2. ALL MATERIALS SHALL COMPLY WITH SPECIFICATIONS AS REQUIRED BY THE FORT WAYNE TRANSPORTATION ENGINEERING DEPARTMENT.
3. CONCRETE SURFACE SHALL BE BROOM FINISH AT RIGHT ANGLES TO TRAFFIC FLOW.
4. CONCRETE PATCHING ON RESIDENTIAL/LOCAL STREETS SHALL CONSIST OF PLACING CLASS A, 4000 PSI, SIX (6) BAG MIX, 564 LBS. OF PORTLAND CEMENT PER CUBIC YARD AND TO A NINE INCH (9") MINIMUM DEPTH WITH CONTRACTION JOINTS TO MATCH EXISTING JOINT PATTERN. EXCAVATE TO PLACE A TWO INCH (2") COURSE OF COARSE AGGREGATE FOR BASE, NO. 53.

NOTE: A MEDIUM-RANGE, WATER-REDUCING ADMIXTURE MAY BE USED PROVIDING DOSAGE RATES DO NOT EXCEED 9 FL. OZ. PER 100 LBS. OF CEMENTITIOUS MATERIAL SHALL BE DEFINED AS TYPE I PORTLAND CEMENT. ALL OTHER POZZOLANIC MATERIALS SUCH AS FLY ASH, SILICA FUME AND GGBFS (GROUND-GRANULATED BLAST FURNACE SLAG) SHALL NOT BE USED.

5. CONCRETE SLUMPS SHALL NOT EXCEED 4". A MINIMUM OF 550 PSI FLEXURAL STRENGTH MUST BE ACHIEVED PRIOR TO ALLOWING ROADWAY TO BE OPENED TO ANY VEHICULAR TRAFFIC.
6. THE CONCRETE PATCH SHALL BE ANCHORED TO THE EXISTING CONCRETE PAVEMENT ALONG THE LONGITUDINAL JOINT USING #5 DEFORMED REBAR SPACED 3'-0" ON CENTER AND ALONG THE TRANSVERSE JOINT USING #5 DEFORMED REBAR SPACED 2'-0" ON CENTER.
7. THE NEW SURFACE PAVEMENT GRADE SHALL MATCH THE EXISTING SURFACE PAVEMENT GRADE UNLESS OTHERWISE DIRECTED BY CITY REPRESENTATIVE.
8. ALL CONCRETE PATCHES SHALL BE CONSTRUCTED TO THE FULL SLAB OR HALF SLAB CONCRETE JOINTS, JOINT TO JOINT, CENTERLINE TO BACK OF CURB.

DATE: 9/2/15

NOT TO SCALE

APPROVED BY: M.T.

SHEET NO:SECTIONS

Interoffice Memo

Date: December 2, 2015

To: Common Council Members

From: John Clark

RE: Service Agreement WMS52268013-5364 – Annual Contract for Cut Restorations

The contractor shall furnish all labor, insurance, equipment, materials and power for the completion of the project:

Repair of concrete areas and Grass and Soil cuts made when repairing main, services and other water distribution system piping.

Implications of not being approved: This would hinder the restoration of concrete areas of streets and sidewalks disturbed from excavations. It would increase the Cities cost using contracted firms. It would stop the cooperative training program we have with Fort Wayne Community schools and their building trades department.

The contract for Resolution #WMS52268013-5364 was awarded to Anthis Career Center and cost will exceed \$200,000 based on past years history of this work.

Cc: BOW
Diane Brown

File

Public Hearing Date, if applicable _____

Read the first time in full and on motion by Councilman Thomas Smith,
Read the second time by title and referred to the City Utilities
Committee. Read the third time in full and on motion by Councilman
Thomas Smith, placed on passage by the following vote:

	<u>AYES</u>	<u>NAYS</u>	<u>ABSTAINED</u>	<u>ABSENT</u>
<u>TOTAL VOTES</u>	<u>8</u>	_____	_____	<u>1</u>
BENDER	<u>✓</u>	_____	_____	_____
CRAWFORD	<u>✓</u>	_____	_____	_____
DIDIER	<u>✓</u>	_____	_____	_____
HARPER	_____	_____	_____	<u>✓</u>
HINES	<u>✓</u>	_____	_____	_____
JEHL	<u>✓</u>	_____	_____	_____
PADDOCK	<u>✓</u>	_____	_____	_____
SHOAFF	<u>✓</u>	_____	_____	_____
SMITH	<u>✓</u>	_____	_____	_____

DATED: 12-22-15 Michelle D. Chambers
MICHELLE D. CHAMBERS, CITY CLERK

Passed and adopted by the Common Council of the City of Fort Wayne, Indiana, as
(ANNEXATION) (APPROPRIATION) (GENERAL) (SPECIAL) (ZONING) ORDINANCE Special
(RESOLUTION) NO. S-107-15 on the 22nd day of
December, 2015

Michelle D. Chambers ATTEST: John N. Crawford
MICHELLE D. CHAMBERS, CITY CLERK PRESIDING OFFICER

Presented by me to the Mayor of the City of Fort Wayne, Indiana, on the 23rd day
of December, 2015, at the hour of 1:40 o'clock P.M. E.S.T.

Michelle D. Chambers
MICHELLE D. CHAMBERS, CITY CLERK

Approved and signed by me this 28th day of December
2015, at the hour of 9:00 O'clock AM E.S.T.

Thomas C. Henry
THOMAS C. HENRY, MAYOR

BILL NO. S-15-12-04



REPORT OF COMMITTEE ON CITY UTILITIES

DECEMBER 15, 2015

*Thomas Smith, Chair
Martin Bender, Co-Chair
All Council Members*

AN ORDINANCE approving Fort Wayne Construction Trades Development Contractual Agreement - Anthis Career Center - Annual Contract for Cut Restorations - #WMS52268013-5364 between Fort Wayne Community Schools Anthis Career Center and the City of Fort Wayne, Indiana, in connection with the Board of Public Works. **COMMITTEE ON CITY UTILITIES HAVE HAD SAID** Ordinance under consideration and beg leave to report back to the Common Council that said Ordinance

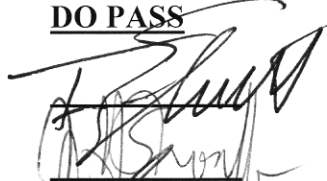
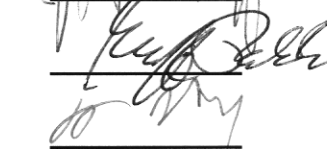
As Amended

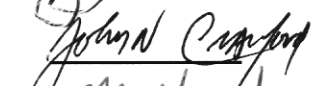
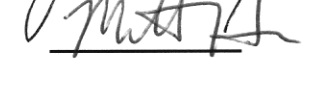
<u>DO PASS</u>	<u>DO NOT PASS</u>	<u>ABSTAIN</u>	<u>NO REC</u>
	_____	_____	_____
	_____	_____	_____
	_____	_____	_____
	_____	_____	_____
	_____	_____	_____
_____	_____	_____	_____
_____	_____	_____	_____

**MICHELLE D. CHAMBERS
CITY CLERK**

